

NUMAX

NUMAX

- [HTTP://WWW.NUMAXTOOLS.COM](http://www.numaxtools.com)
- 1-888-669-5672
- PRIME GLOBAL PRODUCTS, INC.

MODEL: S3GCOMP

3 GALLON OIL-FREE PANCAKE AIR COMPRESSOR

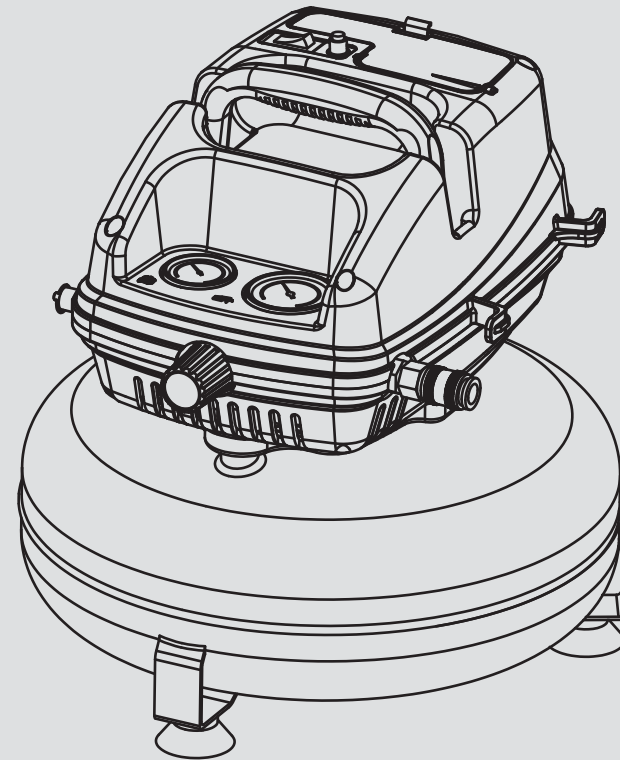

- [HTTP://WWW.NUMAXTOOLS.COM](http://www.numaxtools.com)
- 1-888-669-5672
- PRIME GLOBAL PRODUCTS, INC.



WARNING:

Failure to follow warnings could result in DEATH OR SERIOUS INJURY.

SAVE THIS MANUAL FOR FUTURE REFERENCE.

SYMBOLS	3
GENERAL SAFETY INFORMATION	3-7
PRE-OPERATION	7-10
Specifications	7
Duty Cycle	7
Placement of Air Compressor	8
Attaching the Hose	8
OPERATION	8-11
Preparing for Start-Up	8-9
Starting the Compressor	9
Checking the Safety Valve	9-10
Running the Air Compressor	10
Draining the Tank	11
MAINTENANCE	11-12
General Maintenance	11
CARE AND CLEANING	13
TROUBLESHOOTING	13-15

 **WARNING**

The warning and precautions discussed in this manual cannot cover all possible conditions and situations that may occur. Please be aware of the potential hazards and take all necessary precautions to avoid risk of injuries.



 **SAVE THIS MANUAL**

Keep this manual for the safety warnings, precautions, operations, inspections, and maintenance information. Store this manual and the receipt in a safe and dry place for future reference.

▲ WARNING:
To avoid serious personal injury, do not attempt to use this product until you read the manual thoroughly and understand it completely. Save this manual and review it frequently for safe operation and instructing others who may use this tool.

SYMBOLS

- In this manual, and all instructions provided, the following signal words and meaning are intended to explain the levels of risk associated with this tool.

SYMBOLS	SIGNAL	MEANING
	WARNING	Indicates a potentially hazardous situation, which, if not avoided, could result in death or serious injury.
	CAUTION	Indicates a potentially hazardous situation, which, if not avoided, could result in death or serious injury.
	CAUTION	(Without symbol) Indicates a situation that may result in property damage.

GENERAL SAFETY RULES

CALIFORNIA PROPOSITION 65

▲ WARNING:
This product can expose you to chemicals including lead, which is known to the State of California to cause cancer and birth defects or other reproductive harm. For more information go to www.P65Warnings.ca.gov.

WORK AREA

- **Keep your work area clean and well lit.** Ensure floors are not slippery from wax or dust.
- **Operate the air compressor in an open area at least 18 in. (0.5 M) away from any wall or object that could restrict the flow of fresh air to ventilation openings.**
- **Do not operate power tools in explosive atmospheres, such as in the presence of flammable liquids, gases, or dust.** Power tools create sparks which may ignite the dust or fumes. Keep bystanders, children, and visitors away while operating tools. Distractions can cause you to lose control.
- **Always disconnect the air supply and power supply before making adjustments, servicing a tool, or when a tool is not in use.**

▲ WARNING:
This compressor is not equipped to and should not be used to supply breathing air. Additional equipment would be necessary to properly filter and purify the air to meet minimal specifications for grade D breathing as described in Compressed Gas Association Commodity, Specification G7.1-1966, OSHA 29 CF9 1910.134. Compressed Gas Association, 4211 Walney Road, Fifth Floor, Chantilly, VA 20151-2923, (703) 788-2700, www.cganet.com. Any such additional equipment has not been examined and no implication of proper use for breathing air is intended or implied.

PERSONAL SAFETY

- **Keep proper footing and balance at all times. Proper footing and balance enables better control of the tool in unexpected situations.**
- **Do not use on a ladder or unstable support.**

PERSONAL SAFETY (CONTINUED)

Operating any power tool can result in foreign objects being thrown into your eyes, which can result in severe eye damage.

Before beginning operation, always wear safety goggles, safety glasses with side shields, or a full face shield when needed. Always use eye protection marked to comply with ANSI Z87.1.

Use safety equipment. Always wear eye protection with side shields when operating power tools. A dusk mask, non-skid safety shoes, hard hat, or hearing protection must be used for appropriate conditions.

Stay alert when operating a power tool. Do not use the tool while tired or under the influence of drugs, alcohol, or medication.

● **Do not wear loose clothing or jewelry.** Contain long hair. Keep your hair, clothing, and gloves away from moving parts.

● **Never touch any exposed metal parts on the compressor during or immediately after operation.** The compressor will remain hot for several minutes after operation. Do not reach around protective shrouds or attempt maintenance until the unit has been allowed to cool.

MOVING THE AIR COMPRESSOR

1. Grasp the handle
2. When the location is reached, slowly lower the compressor to the ground. Always store the compressor in a horizontal position resting on the

rubber bumpers. Do not lift by the shroud.

3. When transporting the compressor in a vehicle, trailer, etc., Make sure the tank is drained and the unit is secured with straps to prevent tipping. Use care when driving to prevent tipping the unit over in the vehicle. Damage can occur to the compressor or the surrounding items if the compressor is tipped over.

AIR COMPRESSOR AND PNEUMATIC TOOL SAFETY

1. Keep compressor as far from the working area as possible: at least 15 ft. (4.5 m) from the working area and all explosive vapors.
2. If connected to a circuit protected by fuses, use time delay fuses with this product.
3. Ensure the hose is free from obstructions or snags. Entangled or ensnared hoses may become damaged, or cause loss of balance or footing.
4. Use the air compressor only for its intended use. Do not alter or modify the unit from its original design or function. Never weld or drill holes in the air tank.
5. Never leave a tool unattended with the air hose attached.
6. Do not operate this tool if it does not contain a legible warning label.
7. Do not continue to use a tool or hose that leaks air or does not function properly.
8. Do not attempt to pull or carry the air compressor by the hose.

9. Your tool may require more air consumption than this air compressor is capable of providing.
10. Never direct a jet of compressed air toward people or animals.
11. Protect your lungs. Wear a face or dust mask if the operation is dusty.
12. Do not use this air compressor to spray chemicals. Your lungs can be damaged by inhaling toxic fumes. A respirator may be necessary in dusty environments or when spraying paint.
13. This compressor is equipped with a thermal overload protector which will shut off the motor if it becomes overheated.

⚠ WARNING:
Do not attempt to modify this tool or create accessories not recommended for use with this tool. Any such alteration or modification is misuse and could result in a hazardous condition leading to possible serious personal injury.

⚠ WARNING:
Do not use the compressor in an environment that is dusty or otherwise contaminated. Using the air compressor in this type in environment may cause damage to the unit.

⚠ WARNING:
To reduce risk of electric shock, do not expose the compressor to rain, or operate under inclement weather. Store the compressor indoors when not in use.

⚠ WARNING:
Risk of bursting. Do not adjust the regulator to result in output pressure greater than the marked maximum pressure of the attachment. Do not use at pressure greater than the rated maximum pressure of this compressor.

ELECTRICAL SAFETY (EXTENSION CORDS)

1. Only use 3-wire extension cords that have a 3-prong grounding plugs and 3-pole receptacles that accept the products plug. When using a power tool at a considerable distance from the power source, use an extension cord heavy enough to carry the current that the product will draw. An undersized extension cord will cause a drop in the line voltage, resulting in a loss of power and causing the motor to overheat.
2. Use the chart provided below to determine the minimum wire size required in a extension cord.
3. When operating a power tool outside, use an outdoor extension cord marked “W-A” or “W”. these cords are rated for outdoor use and reduce the risk of electric shock.
4. When using an extension cord, keep it clear of the working area. Position the cord so that it will not get caught on lumber, tools, or other obstructions while you are working with a power tool. Failure to do so can result in serious personal injury.



ELECTRICAL SAFETY (CONTINUED)

Ampere rating (on air compressor data plate)						
	0-2.0	2.1-3.4	3.5-5.0	5.1-7.0	7.1-12.0	12.1-18.0
Cord Length	Wire Size (A.W.G)					
25ft.	16	16	16	16	14	14
50ft.	16	16	16	14	14	12
100ft.	16	16	14	12	10	~
Used in 12-gauge - 20 amp circuit.						

⚠ WARNING:
Check extension cords before each use. If damaged, replace immediately. Never use the air compressor with a damaged cord since touching the damaged area could cause electrical shock resulting in serious personal injury.

⚠ WARNING:
Improperly connecting the equipment grounding conductor can result in a risk of electrical shock.

⚠ CAUTION:
Avoid body contact with grounded surfaces such as pipes, radiators, ranges, and refrigerators. There is an increased risk of electrical shock if your body is grounded.

⚠ CAUTION:
Do not expose power tools to rain or wet conditions. Water entering a power tool will increase risk of electrical shock.

⚠ CAUTION:
Replace damaged cords/wiring immediately. Damaged cords/wiring increases the risk of electrical shock.

NOTICE: Use longer air hoses instead of long extension cords. Your air compressor will run better and last longer.

ELECTRICAL SAFETY (CONNECTION)

1. This air compressor is powered by a precision built electric motor. It should be connected to a power supply that is 120 volts, 60 Hz, AC only (normal household current).
2. Do not operate this tool on a direct current. (DC) A substantial voltage drop will cause a loss of power and the motor will overheat. If the air compressor does not operate when plugged into an outlet, double check the power supply.

ELECTRICAL SAFETY (SPEED AND WIRING)

1. The no-load speed of this product is approximately 4,700 rpm. This speed is not constant and decreases under a load or with lower voltage.
2. For voltage, the wiring in a shop is as important as the motors horsepower rating. A line intended only for lights cannot properly carry a power tool motor. Wire that is heavy enough for a short distance will be too light for a greater distance. A line that can support one power tool may not be able to support two or three products.

ELECTRICAL SAFETY (GROUNDING)

1. This product must be grounded. In the event of an electrical short circuit, grounding reduces the risk of electric shock by providing an escape wire for the electric current. This product is equipped with a cord that has a grounding wire with an appropriate grounding plug. The plug must be plugged into an outlet that is properly installed and grounded in accordance with all local codes and ordinances.

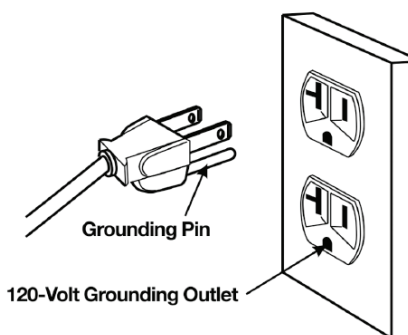

2. Substitution of the word "DANGER" for "WARNING" in not prohibited when the risk associated with the product is such that a situation exists which if not avoided will result in death or serious injury.
3. Check with a qualified electrician or service professional if these instructions are not completely understood or if in doubt as to whether the tool is properly grounded.
4. Do not modify the plug provided; if it will not fit in the outlet, have the proper outlet installed by a qualified electrician.
5. This product is for use on a nominal 120-volt circuit and has a grounding plug similar to the plug shown. Only connect the product to an outlet having the same configuration as the plug. Do not use an adapter with this product.

PRE-OPERATION SPECIFICATIONS

Running Horsepower:	1/2 HP
Air-tank Capacity:	3 Gallons
Air Pressure:	100 PSI max.
Air Delivery:	0.5 CFM @ 90 PSI 0.8 CFM @ 40 PSI
Cut-in Pressure:	80 PSI
Cut-out Pressure:	100 PSI
Lubrication:	Oil Free
Input:	120 V, 60 Hz, 5A
Minimum Branch Circuit Requirement:	5 A
Fuse Type:	Time Delay
Net Weight:	18 lbs

DUTY CYCLE

This air compressor pump can run continuously. However, to prolong the life of your air compressor, it is recommended that a 50% average duty cycle be maintained; that is, the air compressor pump should not be run more than 30 minutes in any given hour.

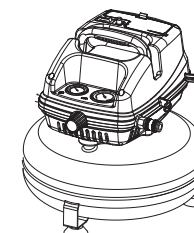

PART (1): Air compressor unit (fully assembled)

PLACEMENT OF AIR COMPRESSOR

▲ WARNING:

If any parts are damaged or missing, do not operate until the parts are replaced. Failure to follow this warning could result in serious personal injury.

▲ CAUTION:

Do not use in an environment that is dusty or otherwise contaminated. Using the air compressor in this type of environment may cause damage to the unit.

1. Place the air compressor in a clean, dry, and well-ventilated area.
2. The air compressor must be positioned at least 18 in. (0.5 m) away from the wall or other obstructions that will interfere with the flow of air.
3. Locate the air compressor as close to the main power supply as possible to avoid using long lengths of electrical wiring.
4. The air filter must be kept clear of obstructions which could reduce the air flow to the air compressor.

ATTACHING THE HOSE

▲ WARNING:

Do not attempt to modify this product or create accessories not recommended for use with this product. Any such alteration or modification is misuse and could result in a hazardous condition leading to possible serious personal injury.

▲ WARNING:

Do not attach air chuck or other tool to the open end of the hose until start-up has been completed.

▲ WARNING:

Do not allow familiarity with products to make you careless. Remember that a careless fraction of a second is sufficient to inflict serious injury.

▲ WARNING:

Always wear safety goggles or glasses with side shields when operating power tools. Failure to do so could result in serious injury.

The compressor is assembled at the factory and ready for use. Check all components to ensure secure assembly. (such as: rubber feet, quick connects, gauges, safety valve, air filter, drain valve, etc.)

1. Make sure the power to the air compressor is disconnected.
2. Rotate the pressure regulator knob fully counterclockwise.
3. Insert the male hose adapter of air hose into the female coupler end in the air compressor.

OPERATION

PREPARING FOR START UP

▲ WARNING:

Risk of unsafe operation. Firmly grasp the air hose in hand when installing or disconnecting to prevent hose whip.

STARTING THE COMPRESSOR

▲ WARNING:

Risk of bursting. If any unusual noise or vibration is noticed, stop the air compressor immediately and have it checked by a trained service technician.

1. Plug the power cord into a proper receptacle.
2. Turn the ON/OFF Switch (A) to the ON position, and allow the tank pressure to build. The motor will stop when the tank pressure reaches “cut-out” pressure.
3. Adjust the regulator knob (C) to a psi setting that is needed for your application- be sure it is within the safety standards required to perform the task.

CHECKING THE SAFETY VALVE

▲ WARNING:

Do not tamper with the safety valve(D). Items loosened from this device could fly up and hit you. Failure to heed this warning could result in death or serious injury. The safety valve automatically releases air when the receiver pressure exceeds the preset maximum. Check the valve before each day of use by pulling the ring by hand.

▲ WARNING:

If air leaks after releasing the safety valve ring or if the valve is stuck, do not use the air compressor until the safety valve has been replaced. Using the air compressor in this condition could result in serious personal injury.

▲ WARNING:

Risk of unsafe operation. Compressed air from the unit may contain water condensation and oil mist. Do not spray unfiltered air at an item that could be damaged by moisture. Some air tools and accessories may require filtered air. Read the instructions for the air tools and accessories.

1. Place the ON/OFF Switch (A) to the OFF position.
2. Close the drain valve (B).
3. Visually inspect the air lines and fittings for leaks.

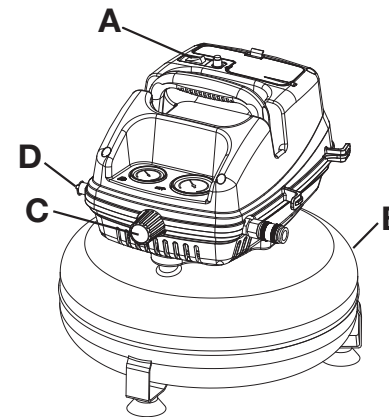

CHECKING THE SAFETY VALVE (CONTINUED)

1. Set the ON/OFF Switch (A) to the ON position and wait for the tank to fill. The compressor automatically shuts off when the pressure reaches the preset maximum.
2. Set the ON/OFF Switch (A) to the OFF position.
3. Pull the ring on the safety valve for 10 seconds to release the air.
4. Release the ring. Air stops escaping at about 20 psi. If air continues to escape after releasing the safety valve ring, discontinue use and seek service before using the air compressor again.

1. Rotate the pressure regulator knob (C) to the desired pressure. Turning the knob clockwise (+) increases air pressure at the outlet; turning counterclockwise (-) reduces air pressure at the outlet.
2. If using an inflation accessory, control the amount of air flow with the pressure regulator knob. Turning the knob fully counterclockwise will completely stop the flow of air.
3. When finished, always drain the tank and unplug the unit. Never leave the unit plugged in and/or running unattended.

RUNNING THE AIR COMPRESSOR

▲ WARNING:
Always ensure the switch is in the OFF position and regulator pressure gauge reads zero before changing air tools or disconnecting the hose from the air outlet. Failure to do so could result in possible serious personal injury.

▲ WARNING:
Your tool may require more air consumption than this air compressor can provide. Check tool manual to avoid damage to the tool or risk personal injury.

NOTICE: Always use the minimum amount of air flow with the pressure regulator knob. Using a higher pressure than needed will drain air from the tank more rapidly and cause the unit to cycle on more frequently.

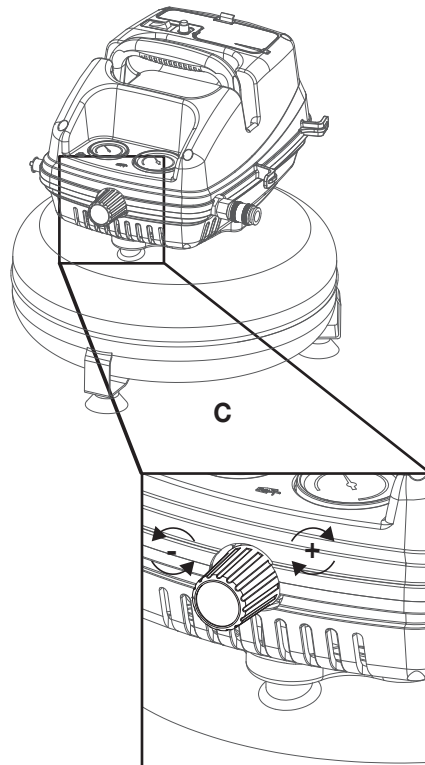

DRAINING THE TANK

▲ DANGER:
Risk of unsafe operation. Air tanks contain high pressure air. Keep face and other body parts away from outlet of drain. Use eye protection [ANSI Z87.1 (CAN/ CSA Z94.3)] when draining as debris can be kicked up into face.

▲ WARNING:
Risk from noise. Use ear protection [ANSI S12.6 (S3.19)] as air flow noise is loud when draining.

▲ WARNING:
Risk of bursting. Water will condense in the air tank. If not drained, water will corrode and weaken the air tank causing a risk of air tank rupture.

NOTICE: All compressed air systems generate condensate that accumulates in any drain point (e.g., tanks, filter, after-coolers, dryers). This condensate contains lubricating oil and/or substances which may be regulated and must be disposed of in accordance with local, state, and federal laws and regulations.

NOTICE: If drain valve is plugged, release all air pressure. The valve can then be removed, cleaned, then reinstalled.

1. Set the ON/ OFF Switch (A) to the OFF position.

2. Slowly bleed the air from the compressor tank by pulling the safety valve (D) to allow the pressure to escape from the tank until the pressure is approximately 20 psi.
3. Drain water from the tank by opening the drain valve (B) on the bottom of the tank.
4. After the water has been drained, close the drain valve (B). The air compressor can now be stored.

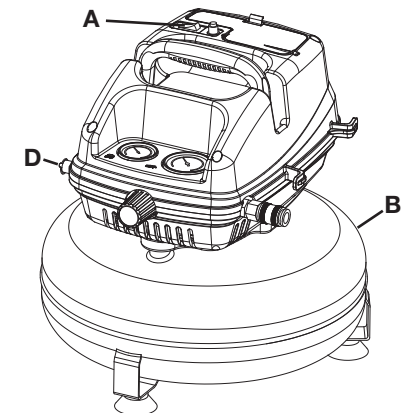

MAINTENANCE

GENERAL MAINTENANCE

1. Condensation forms in the tank when there is humidity in the air. Depending on the environmental conditions, drain the condensate daily and/or every hour. For instructions, see "Draining the Tank" on page 11.
2. The safety valve automatically releases air when the pressure exceeds the preset maximum.

**GENERAL MAINTENANCE
(CONTINUED)**

3. Inspect the tank annually for rust, pin holes, or other imperfections that could cause it to become unsafe.
4. Avoid using solvents when cleaning plastic parts.
5. Most plastics are susceptible to damage from various types of commercial solvents and may be damaged by their use.
6. Use clean cloths to remove dirt, dust, oil, grease, etc.
7. Any service, other than general maintenance, should be performed by an authorized service representative.

▲ WARNING:
Always release all pressure, disconnect from power supply, and allow unit to cool to the touch before cleaning or making repairs on the air compressor.

▲ WARNING:
Do not at any time let brake fluids, gasoline, petroleum-based products, penetrating oils, etc., come in contact with plastic parts. Chemicals can damage, weaken, or destroy plastic which may result in serious personal injury. Electric tools used on fiberglass material, wallboard, spackling compounds, or plaster are subject to accelerated wear and possible premature failure because the fiberglass chips and grindings are highly abrasive to bearings, brushes, commutators, etc. Consequently, we do not recommend using this tool for extended work on these types of materials. However, if you do work with any of these materials, it is extremely important to clean the tool using compressed air.

CARE AND CLEANING

1. Drain the air tank of moisture after operation.
2. When not in use, store the compressor in a cool, dry place.
3. Disconnect the air hose and hang open ends down to allow any moisture to drain.
4. Protect the electrical cord and air hose from damage (such as being stepped on or run over). Wind them loosely around the compressor handle.

TROUBLESHOOTING

PROBLEM	POSSIBLE CAUSE	CORRECTIVE ACTION
The Compressor does not run.	There is a loss of power or the motor is overheated.	Check for proper use of extension cord.
	There is no power to the unit.	Check to be sure the unit is plugged in.
	The circuit breaker has tripped or a fuse has blown at the main power source.	Check the fuse/breaker.
	The thermal overload protector is actuated.	Turn the air compressor OFF. Unplug air compressor and wait until compressor cools down. Plug the air compressor into an approved outlet. Turn the air compressor ON.

PROBLEM	POSSIBLE CAUSE	CORRECTIVE ACTION
The Compressor does not run.	The pressure switch is bad.	Bring the compressor to a service center.
	The compressor has reached automatic shutoff pressure.	Release the air from the tank until the compressor restarts automatically.
The motor hums while running slowly, or it doesn't run at all.	There is low voltage from the power source.	Call an electrician.
	The wrong gauge wire or length of extension cord is being used.	Check for proper gauge wire and cord length.
	There is a shorted or open motor wiring.	Bring the compressor to a service center.
	There is a defective check valve or unloader.	Bring the compressor to a service center.
The fuses blow or circuit breaker trips repeatedly.	The incorrect fuse type is being used.	Check for the proper fuse.
		Use a time-delay fuse. Disconnect other electrical appliances from the circuit or operate the compressor on its own branch circuit.
	The wrong gauge wire or length of extension cord is used.	Check for the proper gauge wire and cord length.
	There is a defective check valve or unloader.	Bring the compressor to a service center.

PROBLEM	POSSIBLE CAUSE	CORRECTIVE ACTION
The thermal overload protector cuts out repeatedly.	There is low voltage from the power source.	Call an electrician.
	There is a lack of proper ventilation, or the room temperature is too high.	Move the compressor to a well ventilated area.
	The wrong gauge wire or length of extension cord is being used.	Check for proper gauge wire and cord length.
The air receiver pressure drops when the compressor shuts off.	The connections (fittings, tubing, etc.) are loose and leaking.	Check all connections with a soap and water solution and tighten.
	The drain valve is loose or open.	Tighten the drain valve.
	The check valve is leaking.	Bring the compressor to a service center.
There is excessive moisture in the discharged air.	There is excessive water in the air tank.	Drain the tank.
	The compressor is working under a high humidity environment.	Move the compressor to an area of less humidity; use an air line filter.
The compressor continuously runs.	The pressure switch is defective.	Bring the compressor to a service center.
	An excessive amount of air is being used.	Decrease the air usage; the compressor is not large enough for the tool's requirement.
The air output is lower than normal.	The inlet valves are broken.	Bring the compressor to a service center.
	The connections (fittings, tubing, etc.) are loose and leaking.	Tighten the connections.

NUMAX

NUMAX

MODEL: SC22US

- [HTTP://WWW.NUMAXTOOLS.COM](http://www.numaxtools.com)
- 1-888-669-5672
- PRIME GLOBAL PRODUCTS, INC.

22GA. UPHOLSTERY STAPLER

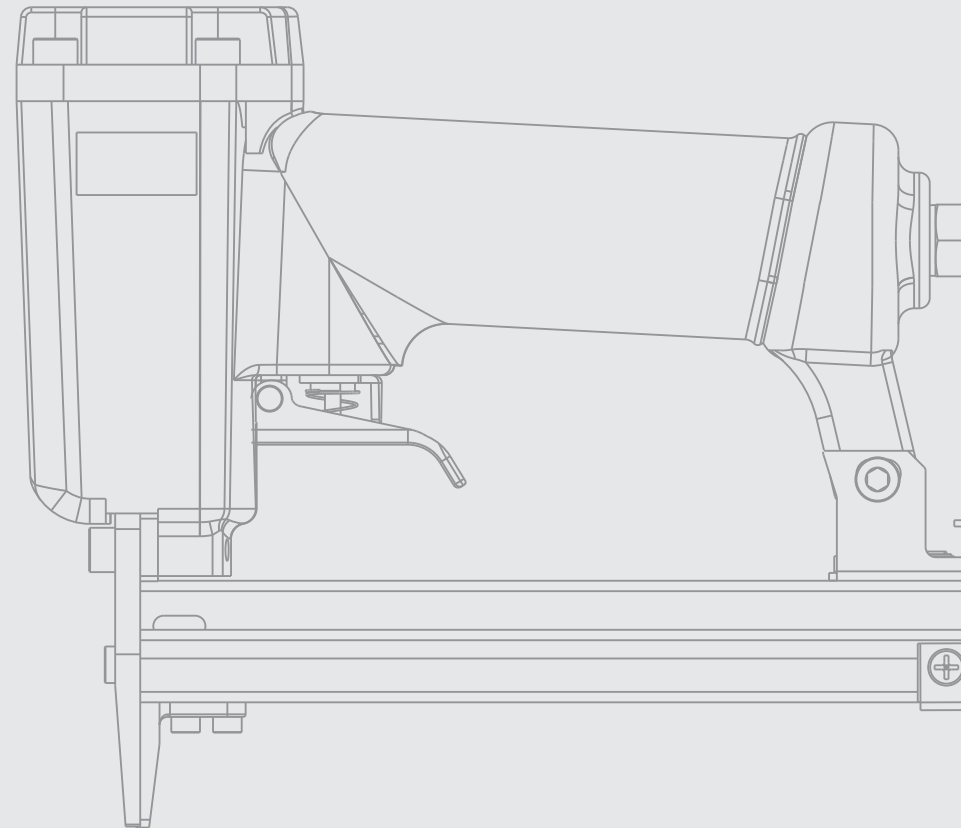

WARNING:

Failure to follow warnings could result in DEATH OR SERIOUS INJURY.

SAVE THIS MANUAL FOR FUTURE REFERENCE.

- [HTTP://WWW.NUMAXTOOLS.COM](http://www.numaxtools.com)
- 1-888-669-5672
- PRIME GLOBAL PRODUCTS, INC.

GENERAL SAFETY RULES	P3
UNPACKING	P6
FEATURES	P6
OPERATION	
LOADING FASTENERS	P6
UNLOADING FASTENERS	P7
CLEARING JAMS	P7
SETTING THE AIR PRESSURE	P7
FIRING THE TOOL	P8
MAINTENANCE	P8
RECOMMENDED HOOKUP	P9
TROUBLESHOOTING	P9
WEARING PARTS	P10
WARRANTIES	P10

⚠ WARNING:

The warnings and precautions discussed in the manual cannot cover all possible conditions and situations that may occur. It must be understood by the user that common sense and caution are factors which cannot be built into this product, but must be supplied by the user.

SAVE THIS MANUAL

- Keep this manual for the safety warnings, precautions, operations, inspections and maintenance. Keep this manual and the receipt in a safe and dry place for future reference.

⚠ WARNING:

To avoid serious personal injury, do not attempt to use this product until you read the manual thoroughly and understand it completely. Save this manual and review frequently for continuing safe operation and instructing others who may use this tool.

SYMBOLS

- In this manual, on the labels, packages and all other information provided with this tool. The following signal words and meanings are intended to explain the levels of risk associated with this tool.

SYMBOLS	SIGNAL	MEANING
	WARNING:	Indicates a potentially hazardous situation, which, if not avoided, could result in death or serious injury.
	CAUTION:	Indicates a potentially hazardous situation, which, if not avoided, may result in minor or moderate injury.
	CAUTION:	(Without symbol) Indicates a situation that may result in property damage.

GENERAL SAFETY RULES

INSTRUCTIONS PERTAINING TO A RISK OF FIRE, ELECTRIC SHOCK, OR INJURY TO PERSONS

⚠ WARNING:

When using tools, basic precautions should always be followed, including the following:

CALIFORNIA PROPOSITION 65

⚠ WARNING:

This product or its power cord may contain chemicals known to the State of California to cause cancer and birth defects or other reproductive harm. Wash hands after handling.

WORK AREA

- **Keep the work area clean and well lighted.** Cluttered benches and dark areas increase the risks of accidents.
- **Do not operate the tool in explosive atmospheres, such as in the presence of flammable liquids, gases, or dust.** The tool creates a spark which may ignite flammable liquids, gases or dust.
- **Keep bystanders, children, and others away while operating the tool.** Distractions could result in improper use and cause injury.
- **Avoid unintentional misfires.** Always use caution to avoid accidentally firing. Do not point towards yourself or anyone whether it contains fasteners or not.

PERSONAL SAFETY

- **Do not nail on top of another nail.** This is able to cause the nail to be deflected and hit

someone, or cause the tool to react and result in a risk of injury to persons.

- **Remove finger from the trigger when not driving fasteners.** Never carry the tool with finger on trigger, the tool is able to fire a fastener.
- **Always wear eye protection.** Operator and others in the work area should always wear ANSI-approved safety goggles with side shields. Eye protection is used to guard against flying fasteners and debris, which may cause severe eye injury.
- **Always wear hearing protection when using the tool.** Prolonged exposure to high intensity noise may cause hearing loss.
- **Use safety equipment.** A dust mask, non-skid safety shoes and a hard hat must be used for the applicable conditions. Wear a full face shield if you are producing metal filings or wood chips.
- **Dress properly. Do not wear loose clothing or jewelry.** Contain long hair. Keep your hair, clothing, and gloves away from moving parts. Loose clothes, jewelry, or long hair can be caught in moving parts.
- **Stay alert, watch what you are doing and use common sense when operating a power tool.** Do not use tool while tired or under the influence of drugs, alcohol, or medication. A moment of inattention while operating the tool may cause serious injury.
- **Avoid unintentional firing. Keep fingers away from trigger when not driving fasteners, especially when connecting the tool to the air supply.**
- **Keep proper footing and balance at all times.** Proper footing and balance enables better control of the tool in unexpected situations.
- **Do not use on a ladder or unstable supports.** Stable footing on a solid surface enables better control of the tool in unexpected situations.

- **Do not overreach.** Keep proper footing and balance at all times. Proper footing and balance enables better control of the tool in unexpected situations.
- **Do not attach the hose or tool to your body.** Attach the hose to the structure to reduce the risk of loss of balance if the hose shifts.
- **Always assume that the tool contains fasteners.** Do not point the tool toward yourself or anyone whether it contains fasteners or not.
- **Wash hands after handling.** This product or its power cord may contain chemicals known to the State of California to cause cancer and birth defects or other reproductive harm.

TOOL USE AND CARE

- **Know this tool.** Read manual carefully, learn its applications and limitations, as well as the specific potential hazards related to this tool.
- **Use only fasteners that are recommended for your models.** Do not use the wrong fasteners or load the fasteners incorrectly.
- **Check for misalignment or binding of moving parts, breakage of parts, and any other condition that may affect the tool's operation.** If damaged, have the tool serviced before using. Many accidents are caused by poorly maintained tools.
- **Maintain tools with care.** Keep tool clean. A properly maintained tool, reduces the risk of binding and is easier to control.
- **Store tools out of the reach of children and other untrained people.** Tools are dangerous in the hands of untrained users.
- **Check operation of the tool before use.** Do not use the tool if the workpiece contact mechanism is not working correctly as accidental driving of a fastener may occur.
- **Do not use tool if trigger does not actuate properly.** Any tool that cannot be controlled with the trigger is dangerous and must be repaired.
- **Do not force tool.** Use the correct tool for your application. The correct tool will do the job better and safer at the rate for which it is designed.
- **Use clamps or another practical way to secure and support the workpiece to a stable platform.** Holding a tool by hand or against the body is unstable and may lead to loss of control.

- **Keep the tool and its handle dry, clean and free from oil and grease.** Always use a clean cloth when cleaning. Never use brake fluids, gasoline, petroleum-based products, or any strong solvents to clean your tool.
- **Do not use the tool as a hammer.**
- **Never use this tool in a manner that could cause a fastener to be directed toward anything other than the workpiece.**
- **Never use gasoline or other flammable liquids to clean the tool.** Never use the tool in the presence of flammable liquids or gases. Vapors could ignite by a spark and cause an explosion which will result in death or serious personal injury.
- **Do not remove, tamper with, or otherwise cause the trigger lock or trigger to become inoperable.** Do not operate any tool which has been modified in a like fashion. Death or serious personal injury could result.
- **Do not touch the trigger unless driving fasteners.** Never attach air line to tool or carry tool while touching the trigger. The tool could eject a fastener which will result in death or serious personal injury. Also actuate the trigger lock to the safe position when not in use.
- **Always fit tool with a fitting or hose coupling on or near the tool in such a manner that all compressed air in the tool is discharged at the time the fitting or hose coupling is disconnected.** Do not use a check valve or any other fitting which allows air to remain in the tool. Death or serious personal injury could occur.
- **Never place hands or any other body parts in the fastener discharge area of the tool.** The tool might eject a fastener and could result in death or serious personal injury.
- **Never carry the tool by the air hose or pull the hose to move the tool or a compressor.** Keep hoses away from heat, oil and sharp edges. Replace any hose that is damaged, weak or worn. Personal injury or tool damage could occur.
- **Always assume the tool contains fasteners.** Respect the tool as a working implement; no horseplay. Always keep others at a safe distance from the work area in case of accidental discharge of fasteners. Do not point the tool toward yourself or anyone whether it contains fasteners or not. Accidental triggering of the tool could result in death or serious personal injury.

- **Do not drop or throw the tool.** Dropping or throwing the tool can result in damage that will make the tool unusable or unsafe. If the tool has been dropped or thrown, examine the tool closely for bent, cracked or broken parts and air leaks. STOP and repair before using, or serious injury could occur.
- **Avoid using the tool when the magazine is empty.** Accelerated wear on the tool may occur.
- **Clean and check all air supply hoses and fittings before connecting the tool to an air supply.** Replace any damaged or worn hoses or fittings. Tool performance or durability may be reduced.
- **Do not use the tool if it leaks air or does not function properly.**
- **Do not operate the tool if it does not contain a legible warning label.**

TOOL SERVICE

- **Use only accessories that are identified by the manufacturer for the specific tool model.**
- **Use of unauthorized parts or failure to follow maintenance instructions may create a risk of injury.**
- **Use only the lubricants supplied with the tool or specified by the manufacturer.**
- **Tool service must be performed only by qualified repair personnel.**

OPERATION

- **Do not drive fasteners near edge of material.** The workpiece may split causing the fastener or ricochet, injuring you or people around.
- **Do not carry the tool from place to place holding the trigger. Accidental discharge could result.** Choice of triggering method is important. Check manual for triggering options.
- **During normal use the tool will recoil immediately after driving a fastener.** This is a normal function of the tool. Do not attempt to prevent the recoil by holding the tool against the work. Restriction to the recoil can result in a second fastener being driven from the tool. Grip the handle firmly and let the tool do the work. Failure to heed this warning can result in serious personal injury.
- **Do not drive fasteners on top of other fasteners or with the tool at an overly steep angle as this may cause deflection of fasteners which could cause injury.**

- **Do not actuate the tool unless you intend to drive a fastener into the workpiece.**
- **Always handle the tool with care:**
 - ◆ Respect the tool as a working implement.
 - ◆ Never engage in horseplay.
 - ◆ Never pull the trigger unless nose is directed toward the work.
 - ◆ Keep others a safe distance from the tool while tool is in operation as accidental actuation may occur, possibly causing injury.

AIR SUPPLY AND CONNECTIONS

- **The connector on the tool must not hold pressure when air supply is disconnected.** If an incorrect fitting is used, the tool can remain charged with air after disconnecting and thus will be able to drive a fastener even after the air line is disconnected, possibly causing injury.
- **Do not use any type of reactive gases, including, but not limited to, oxygen and combustible gases, as a power source.** Use filtered, lubricated, regulated compressed air only. Use of a reactive gas instead of compressed air may cause the tool to explode which will cause death or serious personal injury.
- **Use only a pressure-regulated compressed air source to limit the air pressure supplied to the tool.** The regulated pressure must not exceed 100 psi. If the regulator fails, the pressure delivered to the tool must not exceed 200 psi. The tool could explode which will cause death or serious personal injury.
- **Always disconnect air source:**
 - ◆ Before unloading or making adjustments.
 - ◆ When maintaining the tool.
 - ◆ When clearing a jam.
 - ◆ When touching the safety yoke.
 - ◆ When tool is not in use.
 - ◆ When moving to a different work area.
Such precautionary measures reduce the risk of injury to persons.

LOADING TOOL

- **Do not load the tool with fasteners when any one of the operating controls is activated.**
- **Never place a hand or any part of body in fastener discharge area of tool.**
- **Never point tool at anyone.**
- **Do not pull the trigger or depress the workpiece contact as accidental actuation may occur, possibly causing injury.**

⚠ WARNING:
The warnings and precautions discussed above cannot cover all possible conditions and situations that may occur. It must be understood by the user that common sense and caution are factors which cannot be built into this product, but must be supplied by the user.

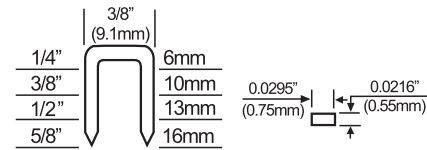

Compatible with Bostitch 22 ga. 71 series 3/8" crown staples.

UNPACKING

- This tool has been shipped completely assembled.
- Carefully remove the tool and any accessories from the box.
- Inspect the tool carefully to make sure no breakage or damage occurred during shipping.
- Do not discard the packing material until you have carefully inspected and satisfactorily operated the tool.
- If any parts are damaged or missing, please call 1-888-669-5672.

⚠ WARNING:
If any parts are missing do not operate this tool until the missing parts are replaced. Failure to do so could result in possible serious personal injury.

⚠ WARNING:
Do not attempt to modify this tool or create accessories not recommended for use with this tool. Any such alteration or modification is misuse and could result in hazardous condition leading to possible serious personal injury.

FEATURES

SPECIFICATIONS

- REQUIRES:** 3.66 SCFM with 100 fasteners per minute @ 90 psi
- AIR INLET:** 1/4 inch NPT
- MAGAZINE CAPACITY:** 150 fasteners
- WEIGHT:** 1.76 lbs
- MAXIMUM PRESSURE:** 100 psi
- PRESSURE RANGE:** 60 psi - 100 psi
- PIN SIZE RANGE:** 1/4 inch to 5/8 inch

FEATURES

- **COMFORT-GRIP HANDLE**
For increased comfort and control.
- **ERGONOMICALLY ENGINEERED BODY**
Rugged and Comfortable debris free, extending tool life.

OPERATION

LOADING FASTENERS

1. Connect the tool to the air source.
2. Depress the latch button(A). Pull back the inner magazine (B).
3. Please load the fasteners with the head of the staples facing the same direction as the work contact element beneath the magazine. **This tool is a bottom loading stapler!**
4. Push the inner magazine(B) forward until latch button pops up.

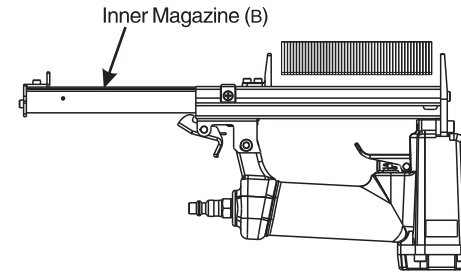
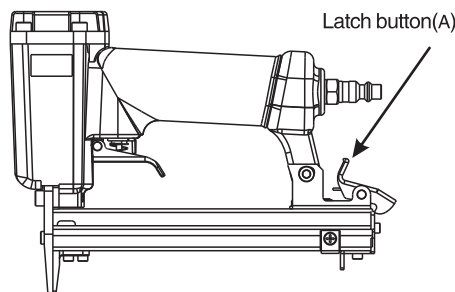

⚠ WARNING:
The tool may fire when it is first connected to the air source. Always connect the tool to the air source before loading fasteners to prevent injury from unintended cycling. Always make sure the tool's magazine is empty at the beginning of each work session, before connecting to an air source.

⚠ WARNING:
Keep the tool pointed away from yourself and others when loading fasteners. Failure to do so could result in possible serious personal injury.

⚠ WARNING:
Use only those fasteners recommended for use with this tool. Fasteners not identified for use with this tool by the tool manufacturer are able to result in a risk of injury to persons or tool damage when used in this tool.

⚠ WARNING:
Never load fasteners with the workpiece contact or trigger activated. Doing so could result in possible serious personal injury.

UNLOADING FASTENERS

Unloading is the reverse of loading, except always disconnect the air source before unloading.

⚠ WARNING:
Always unload all fasteners before removing tool from service.

⚠ WARNING:
Always disconnect the air source before unloading.

CLEARING JAMS

Occasionally, a fastener may become jammed in the firing mechanism of the tool, making the tool inoperable. To remove a jammed fastener, follow the steps below:

1. Disconnect the tool from air source.
2. Pull back the inner magazine(B), and remove the jammed fastener from the nose(C).
3. Reconnect the tool to the air source.
4. Reload the tool with fasteners.

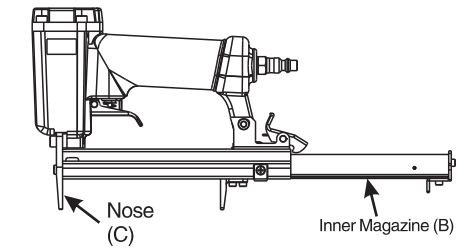

⚠ WARNING:
Make sure there is no fastener in magazine before clearing a jam.

⚠ WARNING:
Disconnect the tool from the air source whenever clearing a jam. After disconnecting the tool from the air compressor, there should still be enough air pressure to fire the tool. After the air hose is disconnected, always fire the tool into scrap wood repeatedly to make sure all of the compressed air is expended.

SETTING THE AIR PRESSURE

The amount of air pressure required depends on the size of the fasteners and the workpiece material. Begin testing the depth of drive by driving a test nail into the same type of workpiece material used for the actual job. Drive a test fastener with the air pressure set at 90-95 psi. Raise or lower the air pressure to find the lowest setting that will perform the job with consistent results. It may be possible to achieve the desired depth with air pressure adjustments alone.

FIRING THE TOOL

1. Disconnect the tool from the air source.
2. Rotate the safety switch (E) from center safety position to the left or right side of trigger.

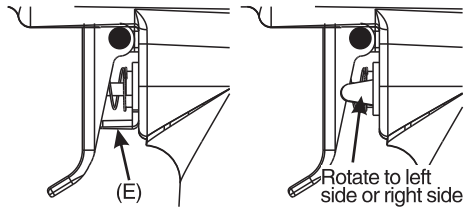

3. Connect the tool to the air source.
4. Grip the tool firmly to maintain control. Position the nose of the tool onto the work surface.
5. Squeeze the trigger to drive a fastener.
6. Turn the safety switch (E) back to center safety position when not using the tool.

⚠ WARNING:
 During normal use the tool will recoil immediately after driving a fastener. This is a normal function of the tool. Do not attempt to prevent the recoil by holding the tool against the work. Restriction to the recoil can result in a second fastener being driven from the tool. Grip the handle firmly and let the tool do the work. Failure to heed this warning can result in serious personal injury.

MAINTENANCE

⚠ WARNING:
 Any time inspection, maintenance, and cleaning are done:
 ♦ Disconnect the tool from the air source.
 ♦ Empty the magazine completely.

ANTI-DUST

Each tool is packed with an anti-dust cap on the air connector, check it after unpacking. Keep the anti-dust cap cover the air connector when the tool is not in use.

LUBRICATION

Frequent, but not excessive, lubrication is required for best performance. Oil for the tool added through the air line connection and will lubricate the internal parts. Do not detergent oil or additives as these lubricants will cause accelerated wear to the seals and bumpers in the tool, resulting in poor tool performance and frequent tool maintenance.

⚠ CAUTION:
 Lubricate tool only with specified lubricants.

CLEANING

Avoid using solvents when cleaning plastic parts. Most plastics are susceptible to damage from various types of commercial solvents and maybe damaged by their use. Use clean cloths to remove dirt, dust, oil, grease, etc.

⚠ WARNING:
 Do not at any time let brake fluids, gasoline, petroleum-based products, penetration oils, ect. come in contact with plastic parts. Chemicals can damage, weaken or destroy plastic which may result in serious personal injury.

COLD WEATHER OPERATION

For cold weather operation, near and below freezing, the moisture in the air line may freeze and prevent tool operation. We recommend the use of air tool lubricant or permanent antifreeze (ethylene glycol) as a cold weather lubricant.

⚠ CAUTION:
 Do not store tools in a cold weather environment to prevent frost or ice formation on the tool's operating valves and mechanisms that could cause tool failure.

RECOMMENDED HOOKUP

1. The air compressor must be able to maintain a minimum of 60 psi when the tool is being used. An inadequate air supply can cause a loss of power and inconsistent driving.
2. An oiler can be used to provide oil circulation through the tool. A filter can be used to remove liquid and solid impurities which can rust or gum up internal parts of the tool.
3. Always use air supply hoses with a minimum working pressure rating equal to or greater than the pressure from the power source if a regulator fails, or 150 psi, whichever is greater. Use 3/8" air hose for runs up to 50' and 3/8" quick coupler on the air hose.
4. Use a pressure regulator on the compressor, with an operating pressure of 0-125 psi. A pressure regulator is required to control the operating pressure of the tool between 60 psi and 100 psi.

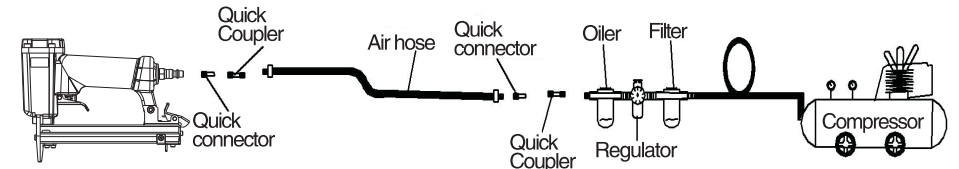

⚠ CAUTION:
 The air compressor must be able to maintain a minimum of 60 psi when the tool is being used. An inadequate air supply can cause a loss of power and inconsistent driving.

⚠ WARNING:
 Do not connect with air compressor which can potentially exceed 200psi. As tool may burst, possibly causing injury.

TROUBLE SHOOTING

⚠ WARNING:
 Stop using tool immediately if any of the following problems occur. Serious personal injury could result. Any repairs or replacements must be done by a qualified service person or an authorized service center.

PROBLEMS	POSSIBLE CAUSE(S)	CORRECTIVE ACTION
Air leaking at trigger valve area.	O-rings in trigger valve housing are damaged.	Replace O-rings.
Air leaking between housing and nose.	Loose screws in housing. 1.Damaged O-rings. 2.Damaged to bumper.	Tighten screws. 1.Replace O-rings. 2.Replace bumper.
Air leaking between housing and cap.	1.Loose screws. 2.Damaged gasket.	1.Tighten screws. 2.Replace gasket.

PROBLEMS	POSSIBLE CAUSE(S)	CORRECTIVE ACTION
Tool skips driving fastener.	1.Worn bumper. 2.Dirt in nose piece. 3.Dirt or damage prevent fasteners or pusher from moving freely in magazine. 4.Damaged pusher spring. 5.Inadequate air flow to tool. 6.Worn O-ring on piston or lack of lubrication. 7.Damaged O-ring on trigger valve. 8.Air leaks. 9.Cap seal leaking.	1.Replace bumper. 2.Clean drive channel. 3.Clean magazine. 4.Replace spring. 5.Check fitting, hose, or compressor. 6.Replace and lubricate O-rings. 7.Replace O-rings. 8.Tighten screws and fittings. 9.Replace gasket.
Tool runs slow or has loss of power.	1.Tool not lubricated sufficiently. 2.Broken spring in cylinder cap. 3.Exhaust port in cap is blocked.	1.Lubricate nailer. 2.Replace spring. 3.Replace damaged internal parts.
Fasteners are jammed in tool.	1.Guide on driver is worn. 2.Fasteners are not correct size. 3.Fasteners are bent. 4.Magazine or nose screws are loose. 5.Driver is damaged.	1.Replace guide. 2.Use only recommended fasteners. 3.Replace with undamaged fasteners. 4.Tighten screws. 5.Replace driver.
<p>▲ WARNING: Use only Numax Authorized Repair Parts. For questions please call 1-888-669-5672 or visit our website at http://www.numaxtools.com</p>		
<p>WEARING PARTS Repair parts can be ordered from our website: http://www.numaxtools.com</p>		



PGP INC. PRODUCT WARRANTIES

1-Year Limited Warranty

This warranty of Numax Nail Guns extends exclusively to the original purchaser of the Numax Nailing Gun one (1) year from the original purchase date. Prime Global Products, Inc.(PGP Inc.) expressly warrants that the Numax Nail Gun is free from defect in materials and workmanship subject to the exceptions and limitations contained herein.

30 Day Limited Warranty

This Warranty of PGP INC.'S driver blades, bumpers, O-rings, piston rings, and gaskets (the Numax Wearing Parts" collectively with the Numax Nailing Guns the "Numax Product") extends exclusively to the original purchaser of the Numax Wearing Parts thirty (30) days from the original purchase date due to a defect in material and workmanship.

PGP Inc. shall repair, replace, or offer full refund, at its option, a Numax Product that has a defect in materials or workmanship. The original purchaser must return the complete Numax Product, postage prepaid and insured, with proof of purchase to PGP Inc. or any of its authorized service centers. Other than the postage and insurance requirement, no charge will be made for repairs covered by this warranty.

These warranties do not apply to defects in materials or workmanship or damages resulting from repairs or alterations which have been made or attempted by others or the unauthorized use of nonconforming parts. They further do not apply if the damage is due to normal wear and tear, abuse, improper maintenance, neglect or accident or caused by use of the Numax Product after partial failure or use with improper accessories.

The Numax Product is intended for use by individuals and not for use on an assembly line, production line, or any commercial application. These warranties do not extend to such commercial use as it constitutes abuse of the Numax Product.

NO WARRANTY, ORAL OR WRITTEN, EXPRESSED OR IMPLIED, OTHER THAN THE ABOVE WARRANTY IS MADE WITH REGARD TO THIS NUMAX PRODUCT. PGP INC. DISCLAIMS ANY IMPLIED WARRANTY OF MERCHANTABILITY OR FITNESS FOR A PARTICULAR USE OR PURPOSE, AND ALL OTHER WARRANTIES. IN NO EVENT SHALL PGP INC. BE LIABLE FOR ANY INCIDENTAL, SPECIAL, CONSEQUENTIAL OR PUNITIVE DAMAGES, OR FOR ANY COSTS, ATTORNEY FEES, EXPENSES, LOSSES OR DELAYS ALLEGED TO BE AS A CONSEQUENCE OF ANY DAMAGE TO, FAILURE OF, OR DEFECT IN ANY PRODUCT INCLUDING, BUT NOT LIMITED TO, ANY CLAIMS FOR LOSS OF PROFITS.

These warranties are the sole and exclusive warranties, express or implied for the Numax Product. No employee, agent, dealer or other person is authorized to alter, modify, expand or reduce the terms of these warranties or to make any other warranty on behalf of PGP Inc. These express limited warranties contains the entire agreement regarding express and implied warranties related to the Numax Product. No writing or languages in the purchase order or any other document shall be construed as an addition or alteration of PGP Inc.'s warranties of the Numax Product.

All matters related to the sale and/or use of the Numax Product that is the subject of these limited warranties, along with the construction and enforcement of the terms of this limited warranties themselves, shall be subject to the laws of the state of Georgia. Any dispute arising out of the sale and/or use of the Numax Product that is the subject of these limited warranties shall be brought in Cherokee County, Georgia. Purchase and/or use of the Numax Product makes you subject to the benefits and limitations of these limited warranties. Accordingly, any writ, judgment or other enforcement, obtained from a jurisdiction, county, parish, state or federal court or other country, other than from the forum identified above, shall be void and unenforceable against PGP Inc.

Some states do not allow limitations on how long an implied warranty lasts, so the above limitations may not apply to you. Some states do not allow the exclusion or limitation of incidental or consequential damages, so the above limitation or exclusion may not apply to you.

If any term or limitation contained in this limited warranty is deemed unenforceable by law, then that term shall be severed from the remaining portions of the limited warranties which shall remain enforceable.

THESE WARRANTIES ARE SUBJECT TO CHANGE WITHOUT NOTICE.